

PELLET MILLS

COMPOUND FEED INDUSTRY





AMANDUS KAHL ACCOMPANIES YOU

on your way to the right decision



AMANDUS KAHL looks back on around 100 years of expertise in manufacturing flat die pellet mills.

The field of "animal nutrition" involves more than just feeding: High-quality processing of individual feed components and flawless production processes promote animal welfare and animal health. Compacting feed into pellets provides several advantages: In addition to improved storage and economic transport, pelleting particularly facilitates feed dosing. This ensures that the animals receive the feed composition they need.

AMANDUS KAHL has been manufacturing flat die pellet mills since the mid-1920s and can look back on around 100 years of expertise in the design and manufacture of pellet mills for various industries. Worldwide, the flat die pellet mill 39-1000 is one of the most successful pellet mills on the market. AMANDUS KAHL pellet mills are characterised by sophisticated technology and quality "Made in Germany".

The machine repertoire for the compound feed sector currently comprises more than 10 types of pellet mills with different sizes that meet our customers' requirements.

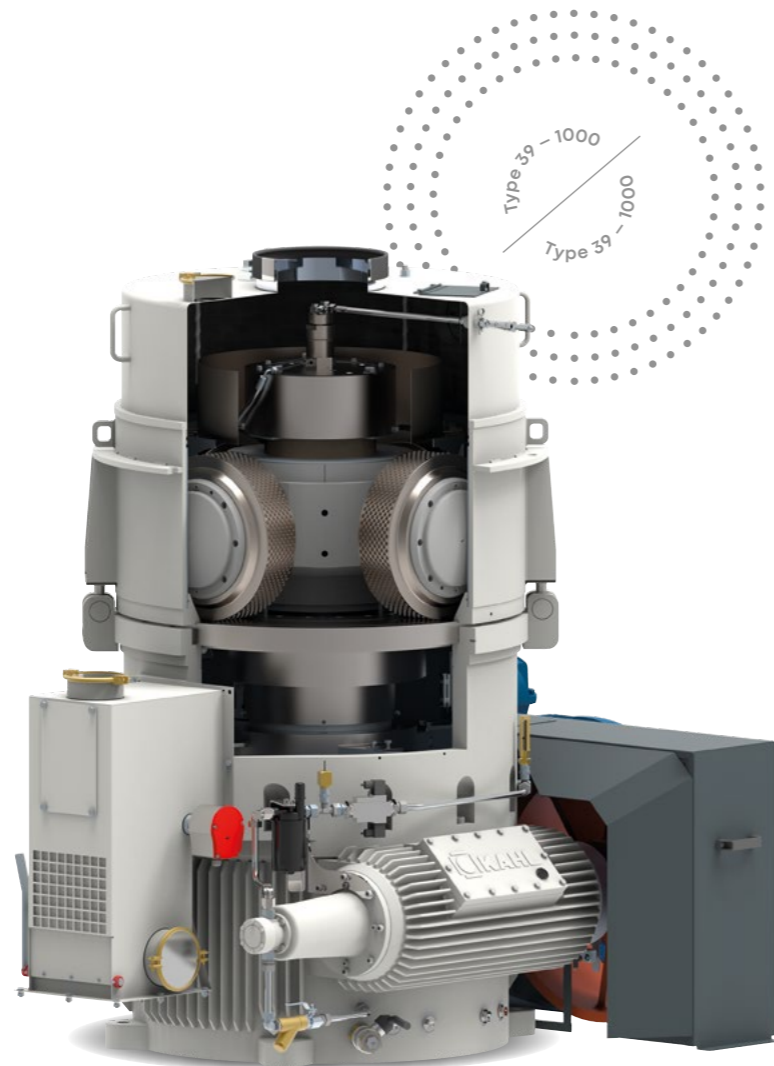

TABLE OF CONTENTS

01

Compound feed pellets
Page 04 – 05

02

Petfood
Page 06 – 07

03

**Pan grinder rollers, dies
and advantages**
Page 08 – 09

04

Pellet mill overviews
Page 10 – 12

05

EAPR system
Page 13

06

Plant diagram, references
Page 14 – 15



COMPOUND FEED PELLETS

For controlled dosing of nutrients and to promote animal health in cattle, poultry and pigs.



The requirements of feed pellets for different animal species differ in terms of length, diameter and composition. KAHL flat die pellet mills can be used to produce pellets for poultry, cattle and pig feeding. KAHL pellet mills are designed for universal use for a wide range of products differing in terms of structure, bulk density, binding strength and particle size.



Use KAHL flat die pellet mills to focus on animal welfare, animal health and animal nutrition.



Main fields of application of pelleting

- Compound feed for all animal species, raw materials and mineral mixes
- By-products e.g. from flour mills, oil mills and maltings
- Straw, wood, biomass



↑ Poultry feed pellets



↑ Horse feed pellets



↑ Calf feed pellets



↑ Pig feed pellets



PETFOOD

A quick die change enables the production of differently shaped products



In addition to the typical cylindrical pellets, special shapes for example for horse, cattle and rabbit feeding can also be produced on KAHL pellet mills.

Likewise, dog or cat treats can be produced with low investment costs. The robust dies and maximum production flexibility reflect AMANDUS KAHL's high quality standards.



For more variety:
Go for pellet shapes such as
cloverleaves or square pellets



↑ Even rabbits benefit from the special shapes



↑ Dogfood



↑ Horse feed



↑ Rabbit feed



PAN GRINDER ROLLERS AND DIES

Depending on the field of application, different hardening processes are required, all of which are carried out in KAHL's own hardening shop for pan grinder roller and die production

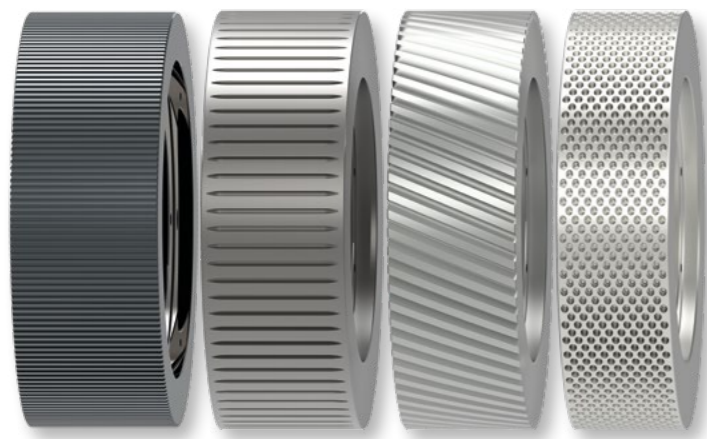

↑ Different pan grinder roller designs



↑ Pan grinder head on flat die



Put an end to loss lubrication and unwanted substances in the feed: Thanks to the axial face seals used by KAHL, lubricants do not penetrate into feed pellets during production.

ADVANTAGES OF KAHL FLAT DIES



Advantages offered by the machine

- High robustness
- Long service life and low wear
- Low consumption of operating materials
- Low lubricant requirement
- Low operating costs
- Fast and easy die change
- Low space requirement and footprint
- Low noise
- Large pelleting chamber for products with low bulk density
- Large pan grinder rollers with low circumferential speed
- Adjustable pressure due to hydraulic system and thus easier machine start
- Product feeding by gravity
- Low maintenance – remote diagnosis possible
- Axial face seals of the pan grinder rollers

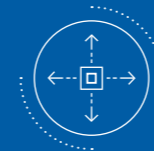

Advantages for the products to be pelleted

- No lubricant in the product
- Highest flexibility for pelleting raw materials
- High pellet quality



Advantages offered by AMANDUS KAHL

- High vertical range of manufacture
- Long-term service also after commissioning
- 10 different pellet mill sizes for feed pellets





PELLET MILLS

Compound feed industry

Type	14-175
Die diameter mm	175
Roller diameter/width mm	130/up to 27
Number of rollers	2
Roller speed m/s	0,5 to 0,8
Drive motor kW/min-1	3

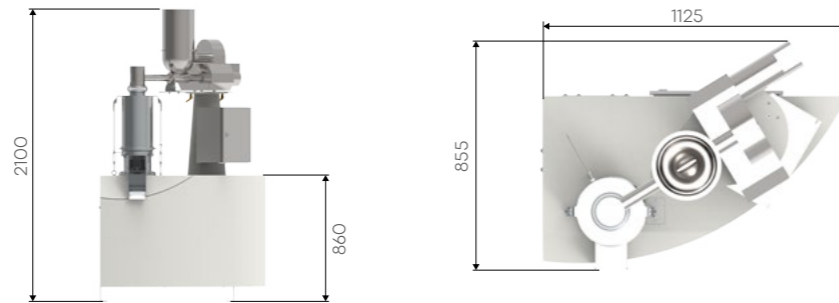

Type	33-390
Die diameter mm	390
Roller diameter/width mm	230/up to 75
Number of rollers	2
Roller speed m/s	2,5
Drive motor kW/min-1	15-30/1500

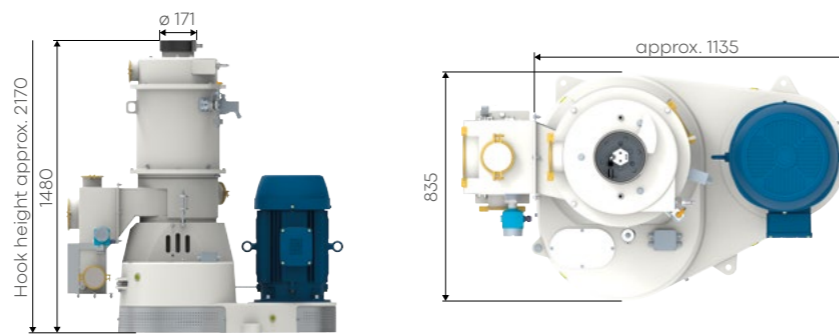

Type	33-500
Die diameter mm	500
Roller diameter/width mm	230/up to 75
Number of rollers	3
Roller speed m/s	2,5
Drive motor kW/min-1	15-30/1500

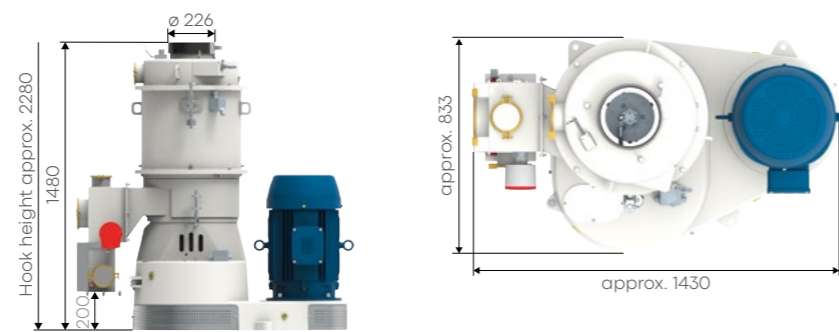

Type	38-600
Die diameter mm	600
Roller diameter/width mm	280/up to 100
Number of rollers	3-4
Roller speed m/s	2,5
Drive motor kW/min-1	55-90/1500

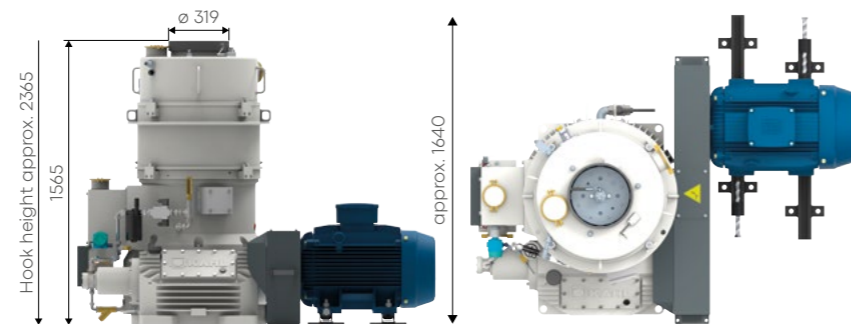

Type	38-780
Die diameter mm	780
Roller diameter/width mm	280/up to 100 or 350/up to 100
Number of rollers	3-5
Roller speed m/s	2,5
Drive motor kW/min-1	75-110/1500

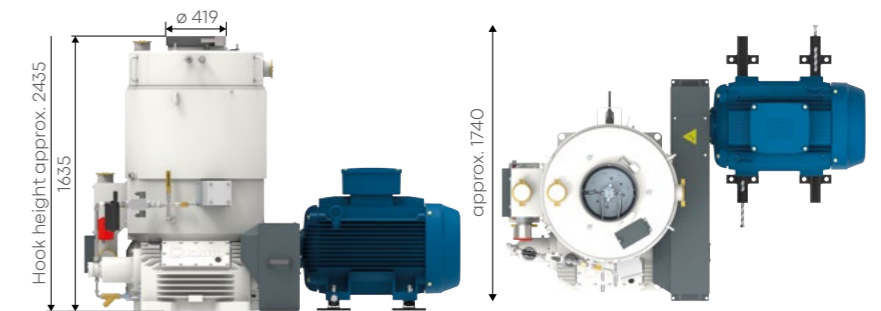

Type	37-850
Die diameter mm	850
Roller diameter/width mm	350/up to 130
Number of rollers	3-5
Roller speed m/s	2,5
Drive motor kW/min-1	132-160/1500

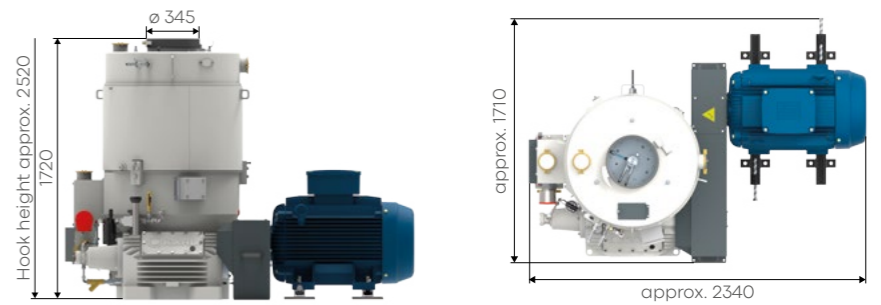

Type	39-1000
Die diameter mm	1000
Roller diameter/width mm	350/up to 154 or 450/up to 154
Number of rollers	3-5
Roller speed m/s	2,5
Drive motor kW/min-1	160-200/1500

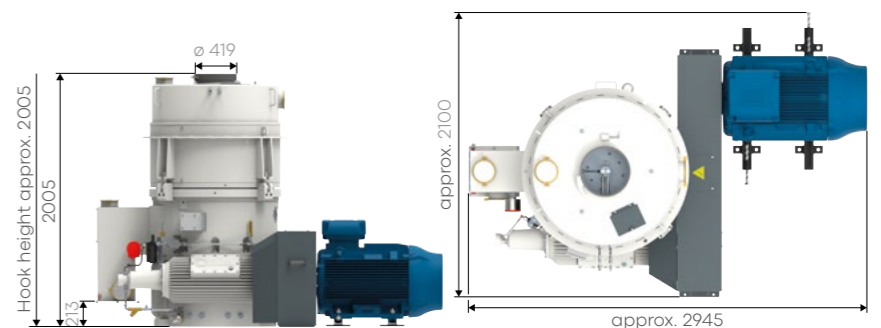

Type	45-1250
Die diameter mm	1250
Roller diameter/width mm	350 up to 130 or 450/up to 190
Number of rollers	3-6
Roller speed m/s	2,5
Drive motor kW/min-1	200-315/1500

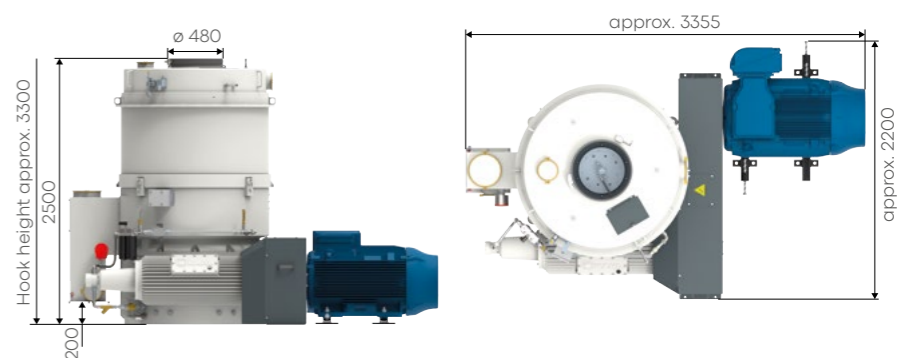



PELLET MILLS

Compound feed industry

Type	60-1250
Die diameter mm	1250
Roller diameter/width mm	450/up to 190
Number of rollers	4-5
Roller speed m/s	2,5
Drive motor kW/min-1	2x160-200/1500



Type	60-1500
Die diameter mm	1500
Roller diameter/width mm	450/up to 240
Number of rollers	4-6
Roller speed m/s	2,5
Drive motor kW/min-1	2x160-220/1500



Do you have questions regarding the KAHL technology?

We will be happy to answer them and can be reached here:

info@akahl.de
+49 (0)40 727 71-0
akahl.com



AUTOMATION

Electronic automatic pellet mill regulation (EAPR)

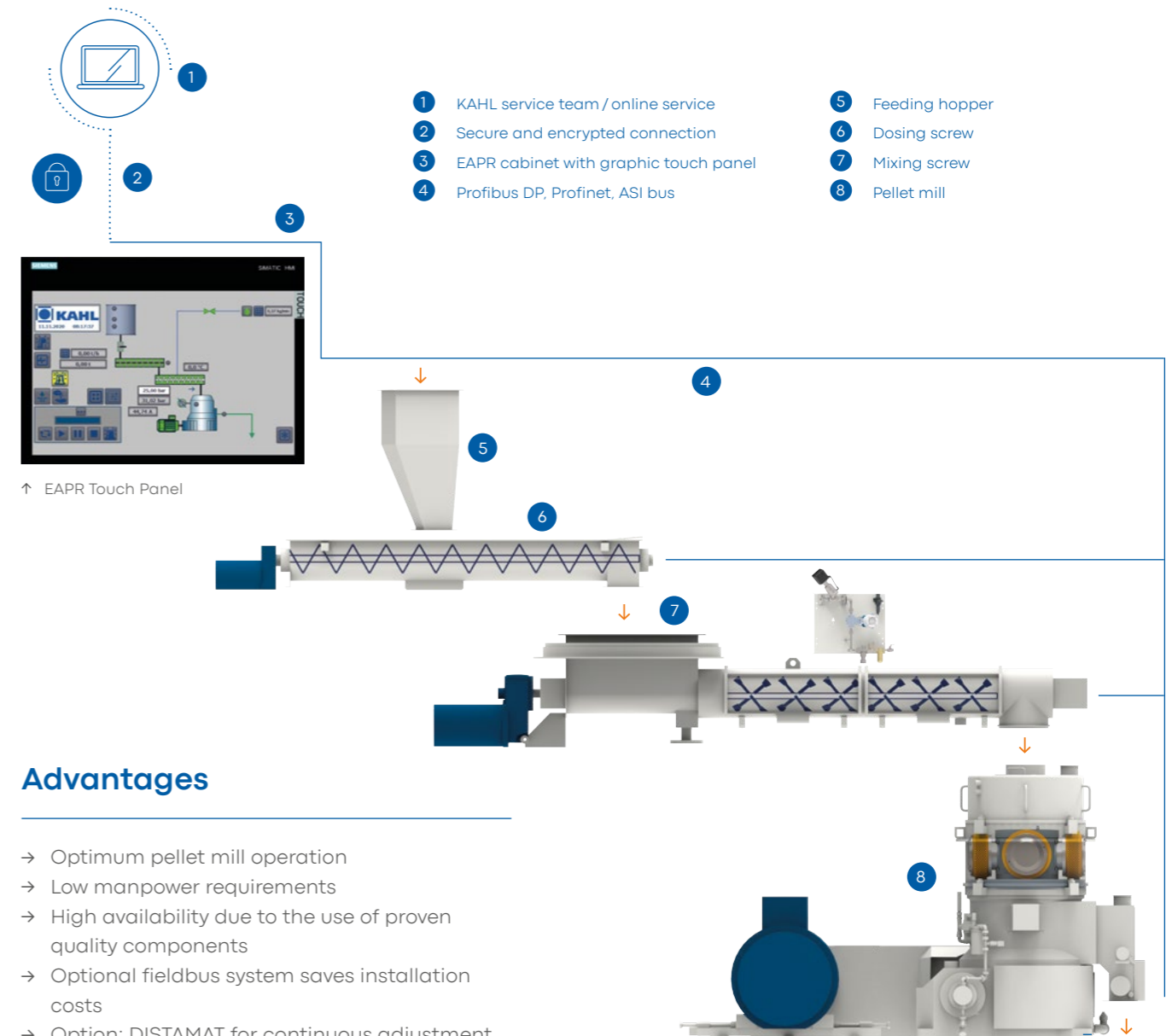

Advantages

- Optimum pellet mill operation
- Low manpower requirements
- High availability due to the use of proven quality components
- Optional fieldbus system saves installation costs
- Option: DISTAMAT for continuous adjustment and control of the roller gap

Switch and control plants for all plant sizes are programmed by AMANDUS KAHL and installed in the respective hardware product. Our electronics engineers develop customised user software to ensure a high level of operational reliability.

The control system EAPR ensures optimum, automatic operation of the flat die pellet mills made by KAHL. The EAPR controls and regulates all relevant process parameters.



PLANTS

Pelleting plants for feedstuff

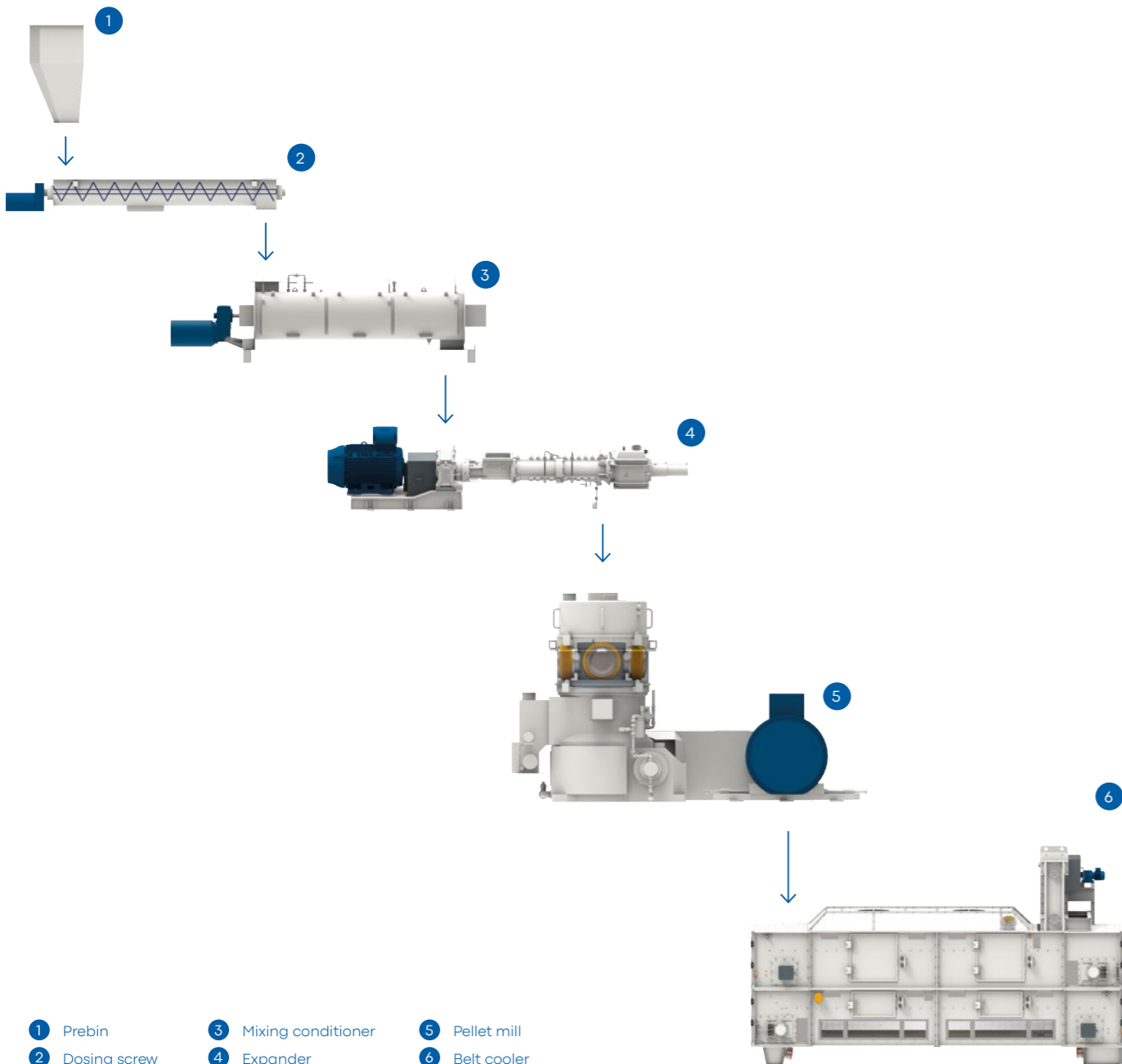

REFERENCES



↑ Compound feed plant: throughput capacity up to 210,000 t/a



↑ Compound feed plant: throughput capacity up to 245,000 t/a



↑
Learn more about our compound feed plant in
Egypt (throughput capacity up to 300,000 t/a)
Scan the QR code now



Service hotline
+49 (0)40 228 542 00



Visit our online shop
shop.akahl.de

AMANDUS KAHL GmbH & Co. KG

Dieselstrasse 5 – 9
21465 Reinbek
Germany

+49 (0)40 727 71-0
info@akahl.de
akahl.com



Directly to the online shop:
Scan the QR code now